



Elite 2340

C u r v e d

Checklist

- Graphic Panel and Visual Image sizes have been checked with Spyder Graphics
- File has been set up to 1/4 of the size of the display (25%)
eg: 2100mm high = 525mm high
- Display has been set up as one as one document
- Bleeds of at least 5mm have been allowed where required
- Text has been converted to curves or embedded
- Logos have been supplied as vector art or 300dpi at 1/4 of the final image size
- Photographic images have been supplied at no less than 300dpi at 1/4 the final size and are CMYK
- Artwork has been checked at full size (400% view) for accuracy, pixelation and overall "sharpness"
- A hard copy proof or pdf of the artwork has been sent clearly indicating crop marks and PMS or spot colours.**



Freecall: 1800 077 218

Phone: 07 3802 5888

Freefax: 1800 455 668

www.spyder.com.au

Email: kylie.dye@spyder.com.au

6 Babbdoyle Street, Loganholme 4129

System Specifications

- Roll-up panels fit via magnet-to-magnet attachment
- Seamless effect suits single image display
- Pop-up frame curved or flat made to any width
- Fabric or graphic finish
- System supplied in case on wheels
- TV shelf, lights and stabilising feet are easily attached to main structure
- One person set-up in seconds
- 10 year guarantee on hardware
- Maximum 5 day delivery time on all components

Artwork requirements

High res PDF

Adobe Illustrator CS5

Adobe InDesign CS5

Adobe Photoshop CS5

Logos as high-res tiff, eps or pdf

Please **DO NOT** send artwork in Word, Excel, Powerpoint, Publisher, PDF's created in Word or low-res jpeg

Artwork Dimensions

See attached page/s for specific system sizes.

Design tips

LAYOUT

- Do not place small text or people's faces on panel splits. Large text is OK but try to place splits between letters.
- End panels on the Elite system curve around to the back so only the inside half is visible from the front.
- Take care with images, as poor quality or undersize originals will give poor quality results when enlarged on your display.

COLOUR

- Keep the number of colours used to a minimum. If you have corporate colours, it will be beneficial to use them for consumer recognition. Have these colours ready to supply so we can match them accurately.

GRADIENTS

On a large display stepping gradients look ugly. To avoid 'stepping' in Gradients create them in Photoshop NOT a vector program. Adding noise will also help to create smoother gradients.

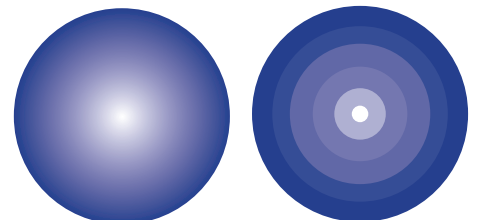

Smooth gradient

Stepping gradient

Contact our Graphics Department with any further questions you may have.

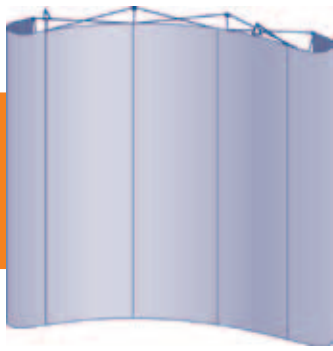

Elite 3x2

C u r v e d

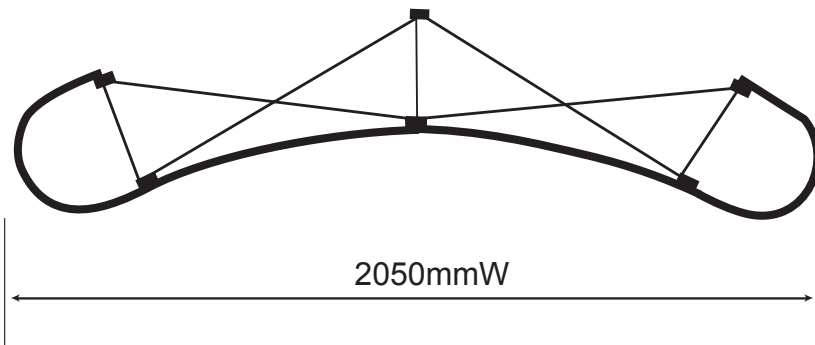
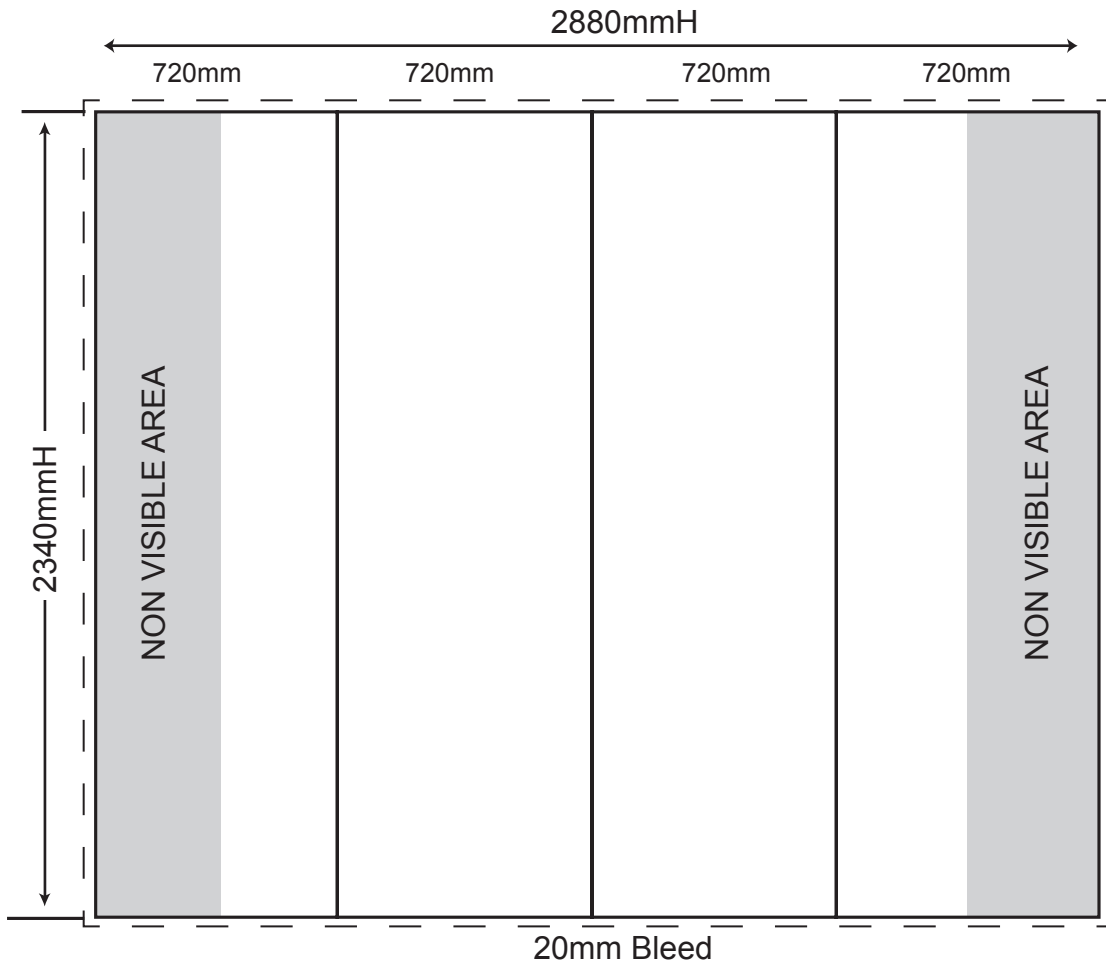

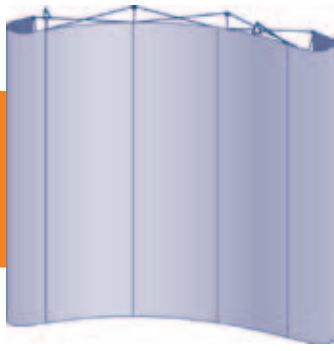

Elite 3x3

C u r v e d

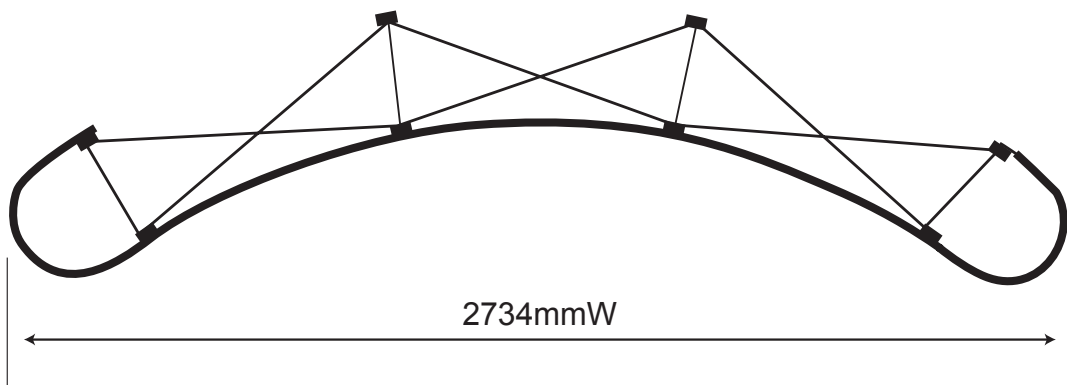
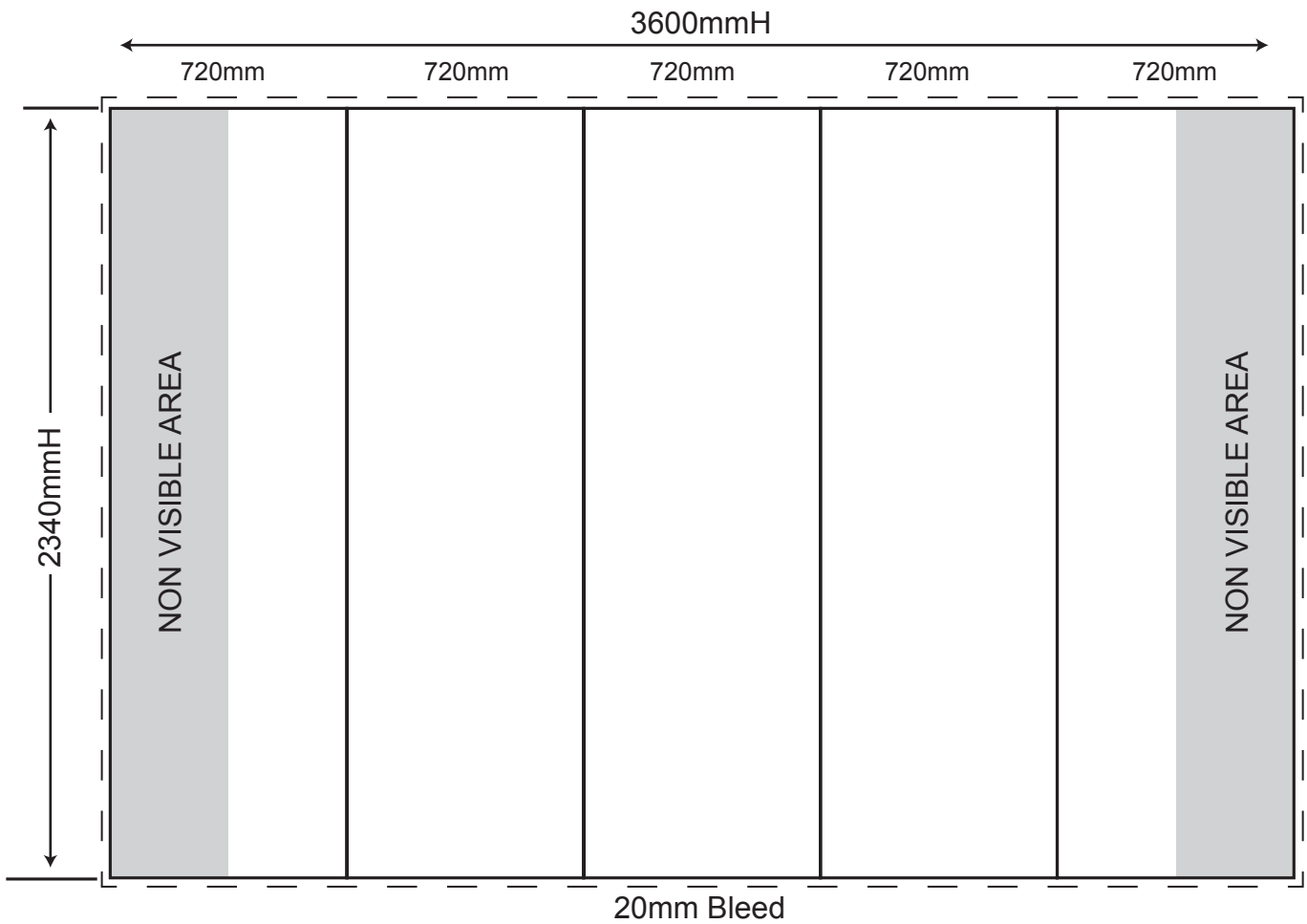

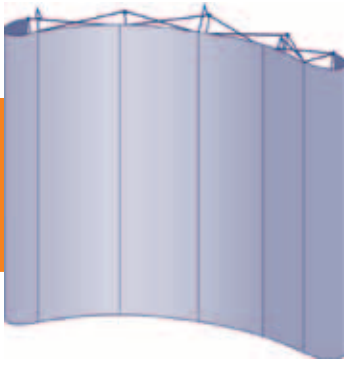

Elite 3x4

C u r v e d

4320mmW

720mm

720mm

720mm

720mm

720mm

720mm

2340mmW

NON VISIBLE AREA

NON VISIBLE AREA

20mm Bleed

